

**The wooden crutch**  
**The adjustable wooden crutch**  
**The bamboo crutch**

# The crutch



# The crutch

- The wooden crutch**
- The adjustable wooden crutch**
- The bamboo crutch**

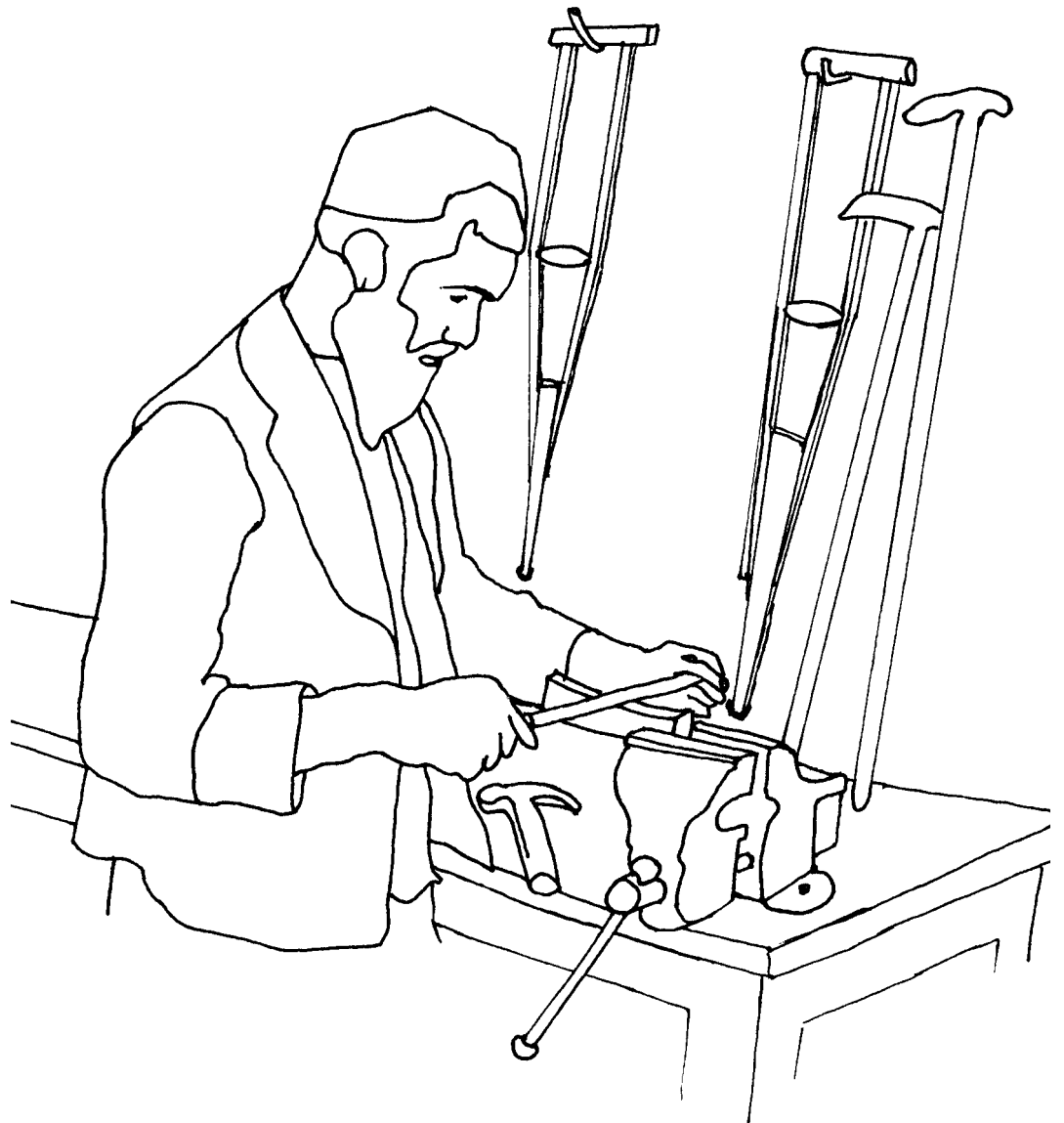

**Authors**

Collective work from the department of technical editions, and the Mozambique and  
Laos teams of Handicap International

**Director of publication**

Serge Rochatte

**Rewriting**

Aline Robert

**Translation**

Adonis Valencia

**Composition**

Xavier Levet et Frédéric Escoffier

**Printing**

MEDCOM 20, rue Bancel 69007 LYON

**ISBN : 2-909064-09-3**

**Registration of copyright : 4<sup>th</sup> trimester 1993**

Available in French, "La béquille", ISBN number : 2-909064-08-5

# The wooden crutch

- easy to manufacture
- for adults and for children

4 The crutch

The crutch

The different parts of the crutch

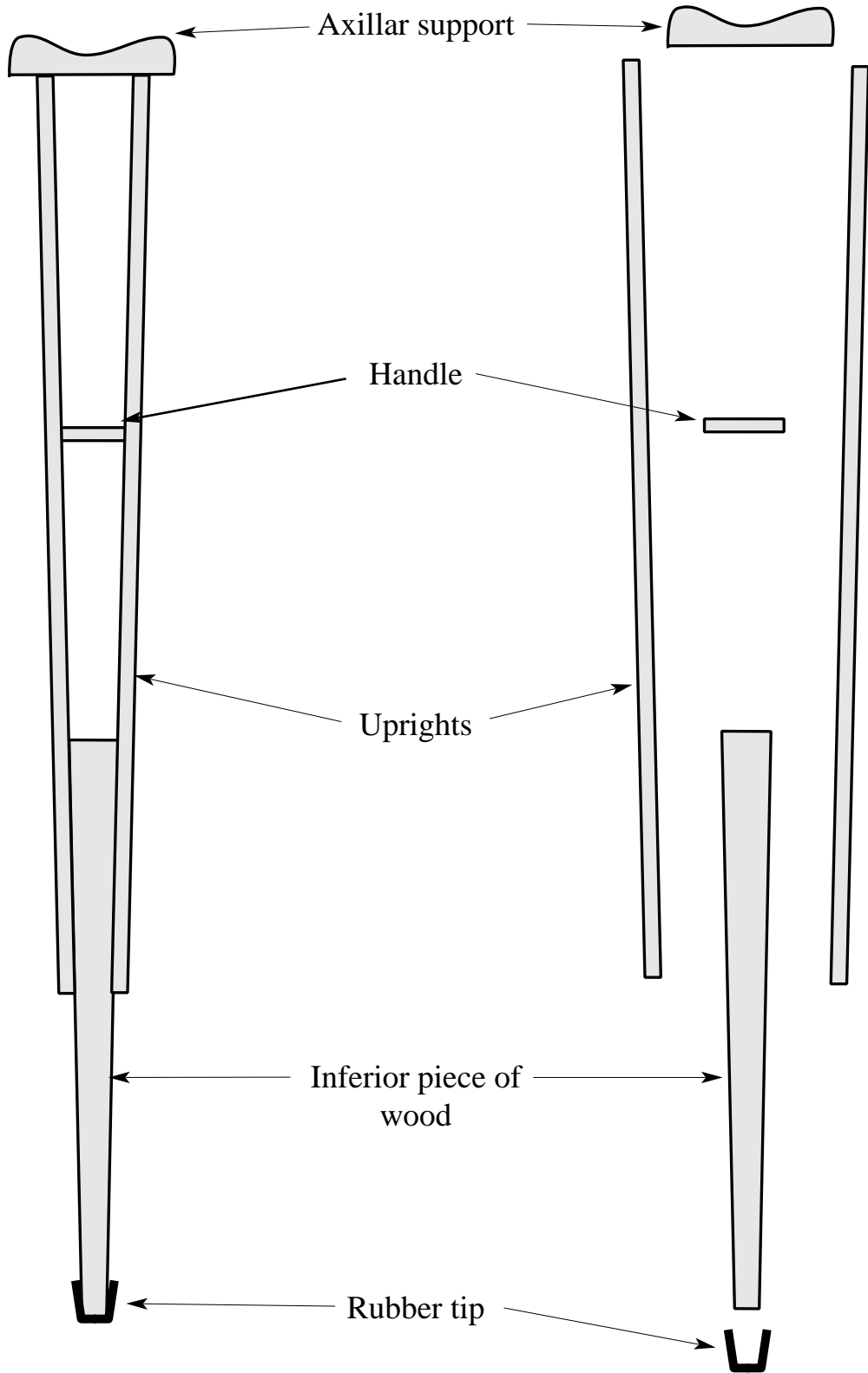

The wooden crutch

## What do you need to manufacture this crutch ?

### Materials :

**Wood :** you must choose a hard or half hard wood, solid, supple but not too heavy. Ask the local craftsmen which is the best suited type of wood. For the same quality, always use the lightest wood. Examples of wood used in our workshops : ceddar, oak, mulberry tree, eucalyptus, niangou, mahogany, fake-mahogany, ha yang, umbila...

*Important :* the wood must be dry, have a straight grain and no knot.

**Nails :** 50 et 25mm

**Tyre pieces**

**Glue**

### Tools :

saw  
grater  
wood scissors  
hammer  
mallet  
pincers  
plane  
square  
metre rule  
pencil

### Measures :

You must know two measures :

#### **the crutch total height :**

The patient is in standing position, with his shoes (if he is usually wearing shoes), the arms hanging along the body, the shoulders should be down, in natural anatomical position: neither too high, nor too low. Take the length from the floor to three fingers below the axillar.

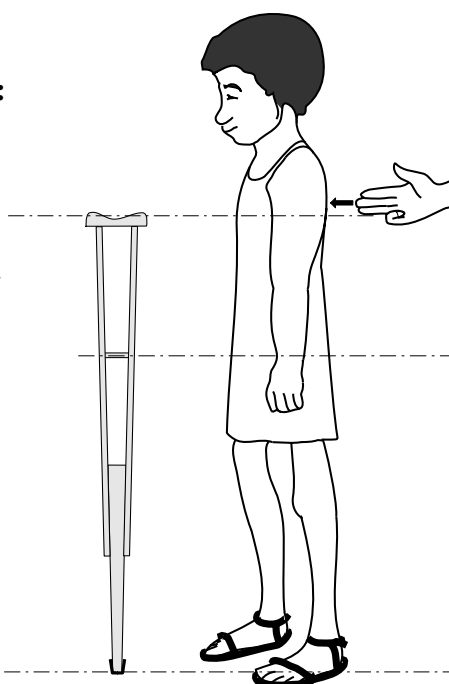

#### **the handle height :**

In the same position, take the length from the floor to the wrist bend : it is the handle height.

These two measures will be useful to adjust the crutch to the patient.

## 6 The crutch

**1<sup>st</sup> step :** cut the different pieces you will need

### Uprights

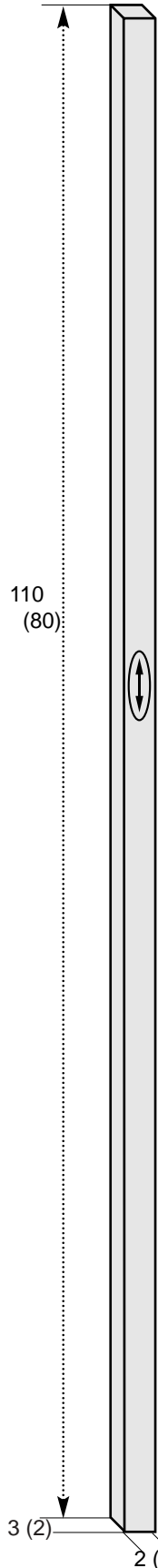

The wooden crutch

### Support

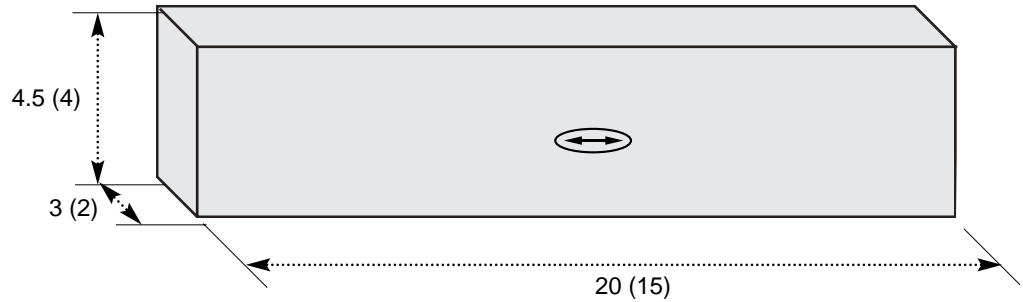

### Handle

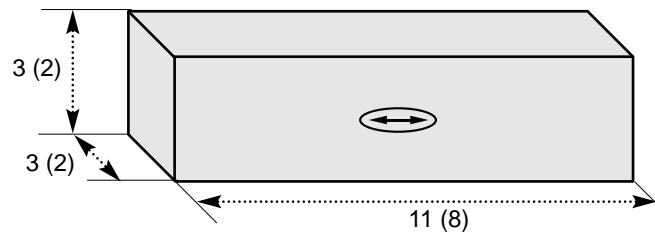

### Inferior piece of wood

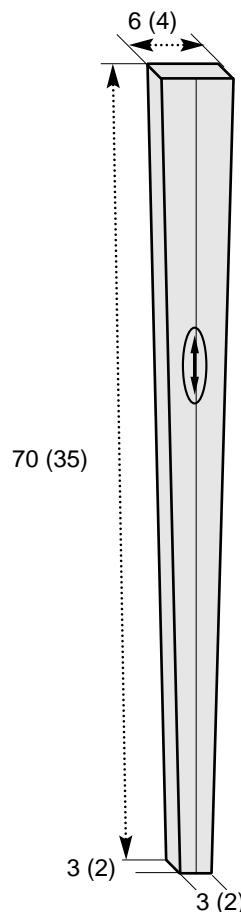

### **Dimensions :**

We give standard measures which are fitted for most cases.

Depending on the height of the person who will receive the crutches, you can change the length of the inferior piece of wood. In Madagascar, we manufacture crutches with an inferior piece of wood, 15 to 20 cm shorter than the length indicated in this manual.

Beside the measure for the adult crutch, we give, between brackets, the measure for the child crutch.

The drawings dimensions are given in centimeters (cm).

We shall indicate the direction of the wood grain with this symbol.



**2<sup>nd</sup> step :** prepare the support

---

→ Hollow the support (see the template at the end of the booklet).

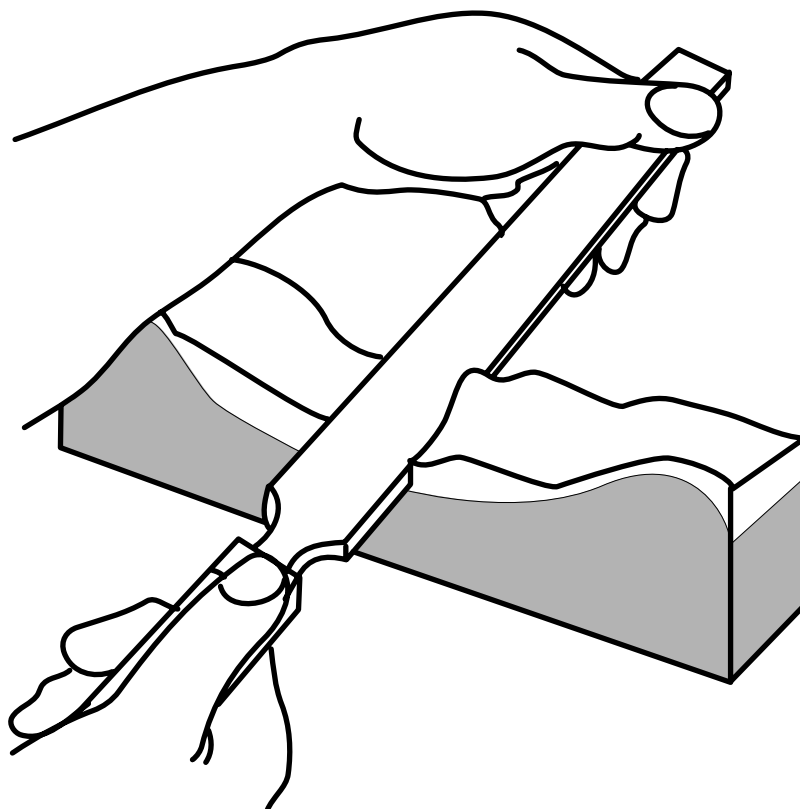

→ Hollow two mortises of 1.5 cm depth, 2(1.5) cm length and 1.5 (1) cm width with the wood scissors.

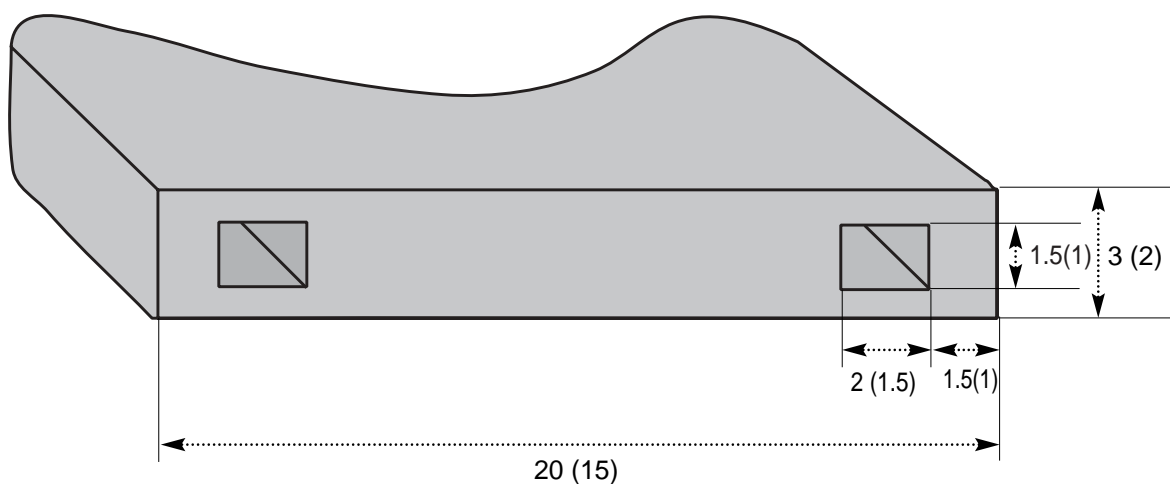

The wooden crutch

**3rd step :** Prepare the uprights

---

→ With the help of the saw and grater, clear a tenon fitted to the support mortise.

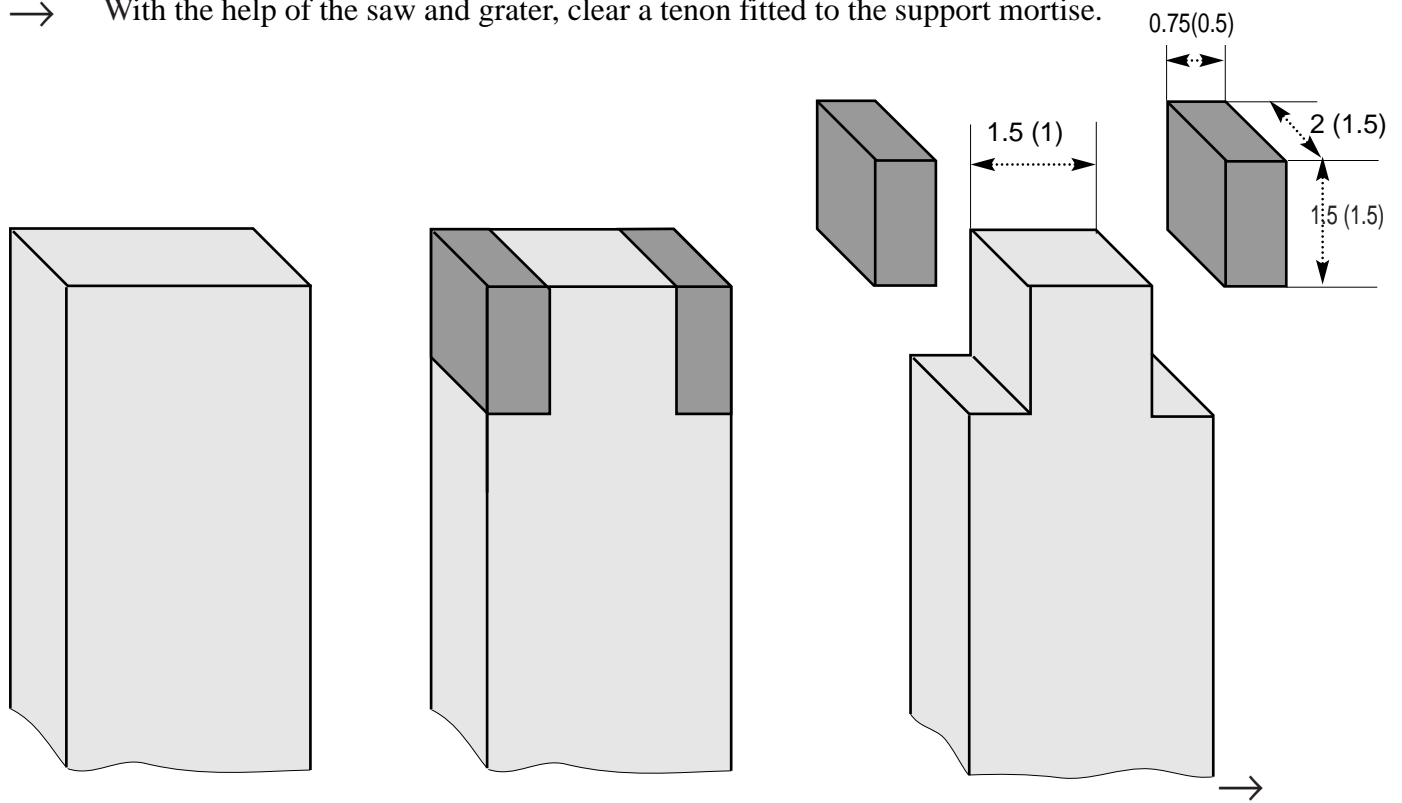

Mark out each tenon with its mortise, then adjust them.

To have a solid assembling, the tenon must fit into the mortise without forcing but without play.

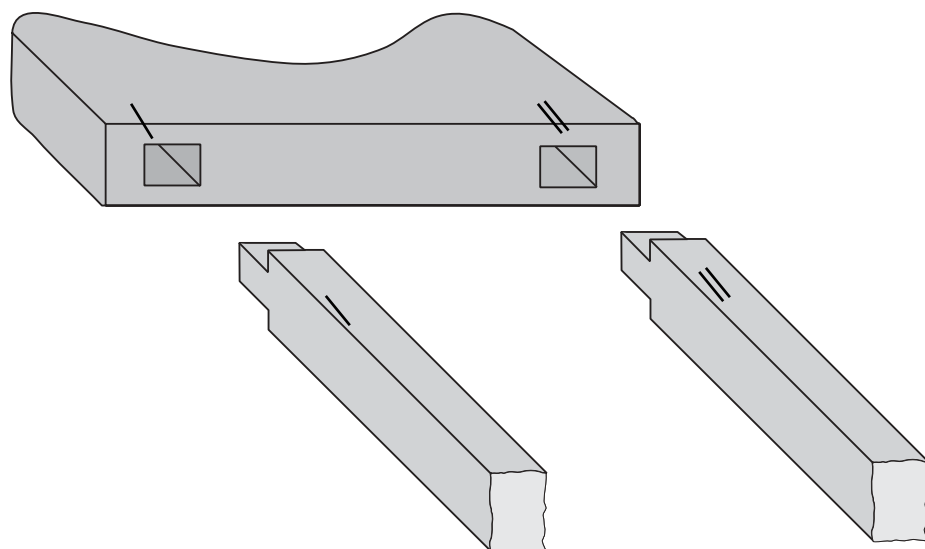

**4<sup>th</sup> step** : Prepare the handle

→ Round off the corners of the wooden piece to obtain a 3 (2) cm diameter bar.

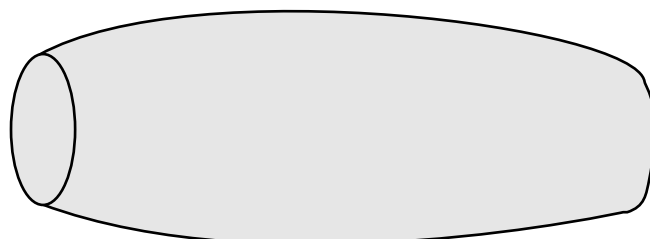
**5<sup>th</sup> step** : Manufacture and fix the rubber tip

It is very important to put a rubber tip on the crutches because it provides a better adherence to a smooth ground and prevents from a quick wear of the inferior piece of wood. We have often seen crutches being worn away by several centimeters within a few months when there was no tip.

→ Cut a tyre strip of 13 X 3 cm for the adult crutch, 13 X 2 cm for the child crutch. To cut it, use a highly sharpened cutting blade and soapy water.

→ Fix the tyre, with the weft inside, on the inferior piece of wood with the help of nails.

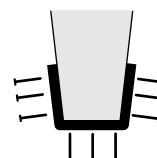
**6<sup>th</sup> step** : Present the unit

→ Put the different pieces down on the work bench. Mark out the position in relation to the uprights to obtain the crutch entire height (the same as the one measured on the patient).

Keep it in position and mark out the handle location on the uprights.

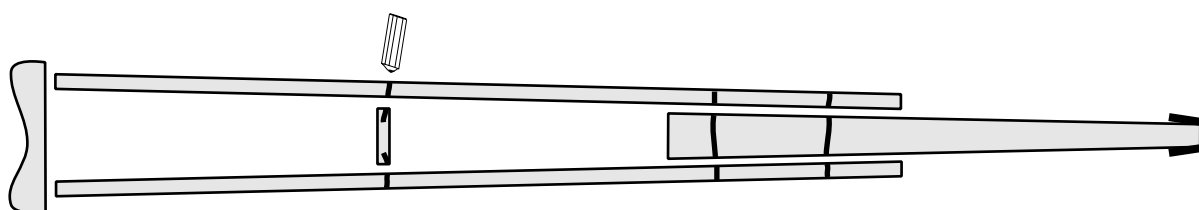

**7<sup>th</sup> step : Final assembly**

Once you have marked out the location of the pieces in relation with each other, you can assemble the pieces in the order you want. We recommend you to start by assembling the tenons mortises, then to fix the handle and finally to place the inferior piece of wood. This method allows you, if need be, to change the crutch total height by modifying the location in relation to the uprights.

**Uprights-support assembling :**

→ Paste the pieces separately, then assemble them.

To fix the assembling, use nails (25 mm).

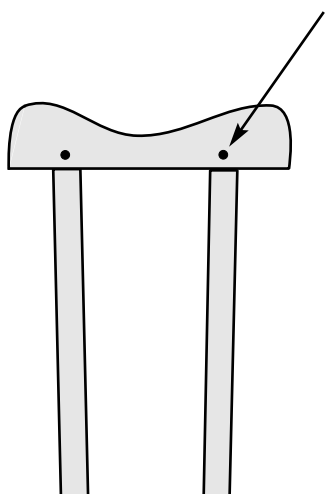



**ALTERNATIVE : assembling with pegs and glue**

**How to manufacture a peg ?**

The square cut pegs are more efficient than the round pegs to fix an assembling. There are less risks of "play" with the time passing and they better absorb the glue.

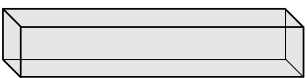
To fit a peg into a hole, cut in hard wood a square cut stick; whose sides are equal to the hole diameter.

- For a 6 mm diameter hole, the peg square section will have a 6 mm side. 
- Then chamfer the faces so as to fit a part of the peg into the hole. 
- To finish you can slightly break the end edges so as to better centre the peg when you place it. 

**Fixing the handle and the inferior piece of wood on the uprights :**

→ Drive several nails of a sufficient length (50 mm) into each end of the handle and into the inferior piece of wood through the uprights.

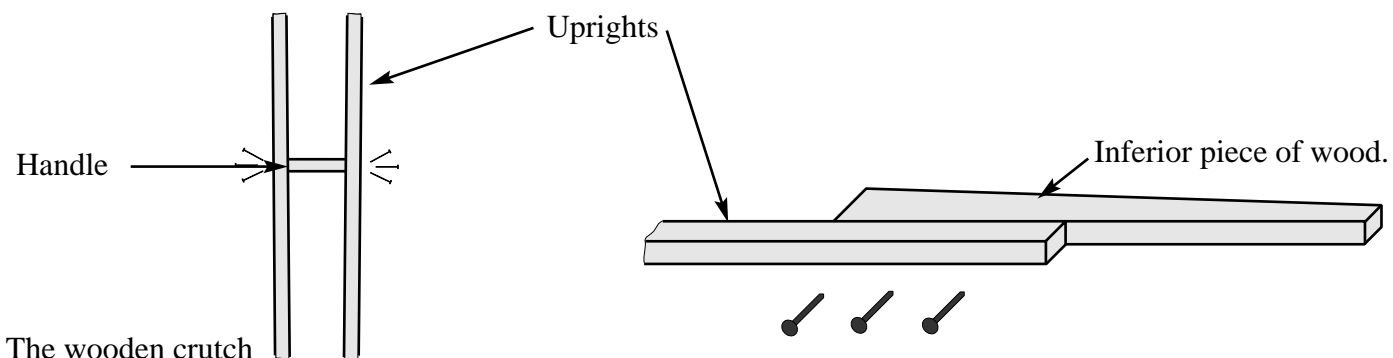

The wooden crutch

## Mounting alternatives

### Fixing with bolts

The mounting can be done with the help of : one 6 mm diameter and 16 (11) cm length bolt for the handle ;  
two 6 mm diameter and 16 (11) cm length bolts for the inferior piece of wood.

→ If you use this technique, you must mark the handle center before rounding it.

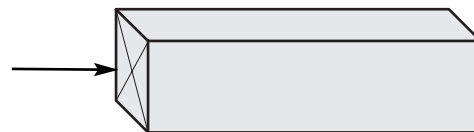

→ Drill a 6 mm hole throughout the uprights, the handle and the inferior piece of wood.

→ Assemble the whole by inserting a washer between the bolt head and the wood and between the nut and the wood.

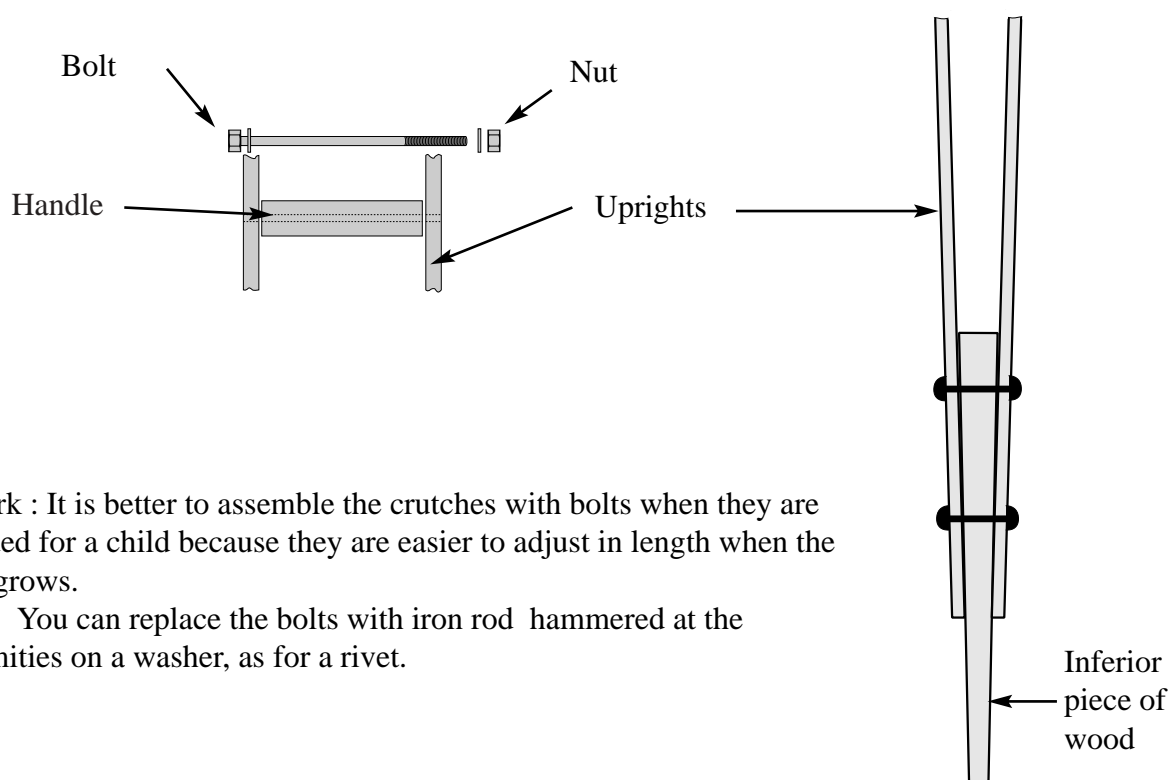

Remark : It is better to assemble the crutches with bolts when they are intended for a child because they are easier to adjust in length when the child grows.

You can replace the bolts with iron rod hammered at the extremities on a washer, as for a rivet.

### Fixing with pins

→ Drill a 6 mm hole, as for the bolts. You are not obliged to pierce right through.

→ Carve pins of 6 mm X 6 mm X 5 cm.

→ Put some wood glue into the holes. Drive the pins in after having pasted them. Keep it pressed until the glue takes effect (generally at least one day).

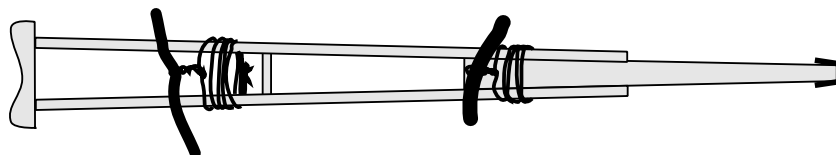

## 8<sup>th</sup> step : Finishings

---

→ Break all the sharp corners with course grained, then fine grained sandpaper.

You can varnish, paint or wax the wood which will thus be less sensitive to humidity and insects.

You can also stuff the support with rags, kapok, etc. Then cover the support with skai or any plastic cloth which will be fixed with small nails or well sewed.

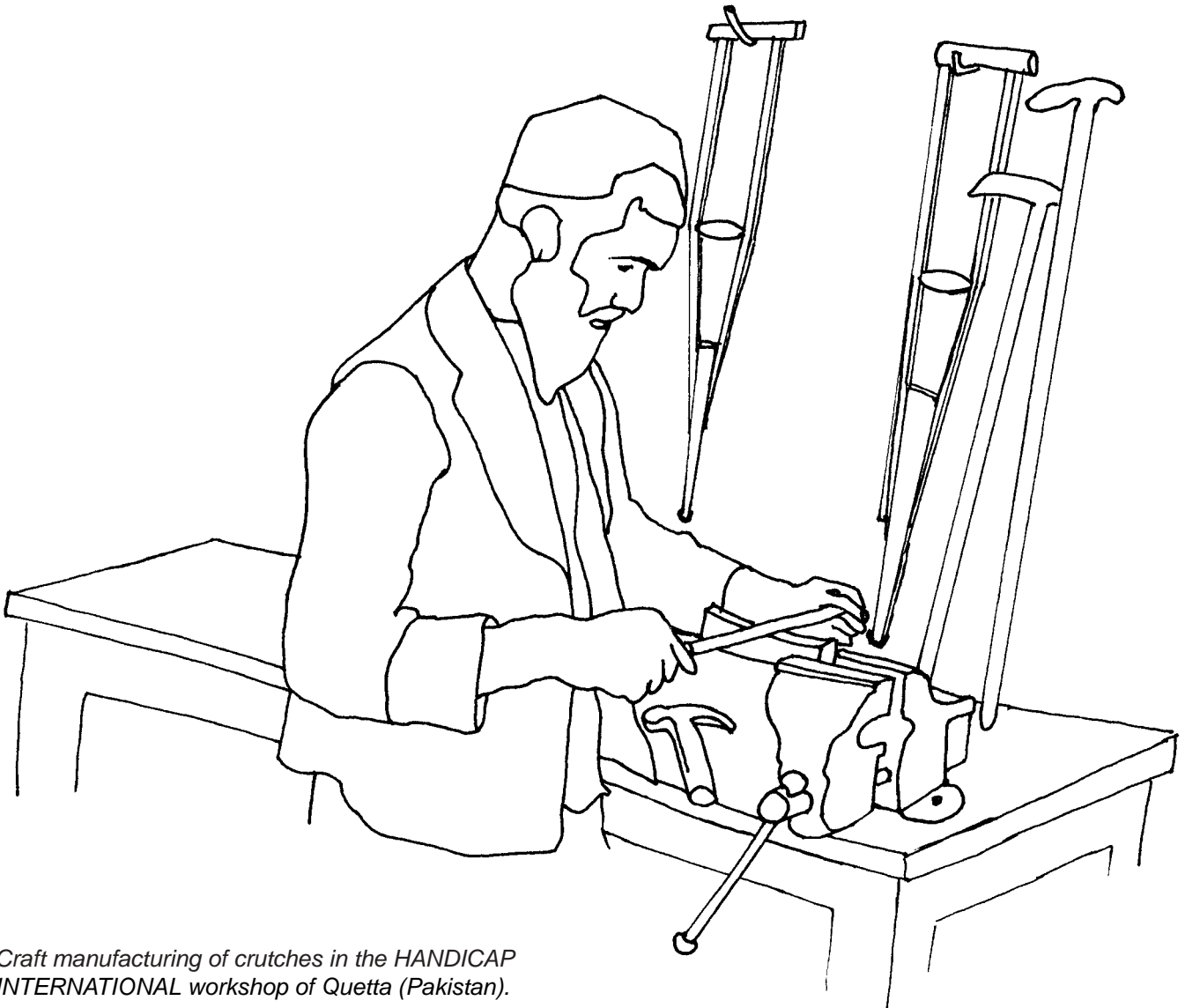

*Craft manufacturing of crutches in the HANDICAP INTERNATIONAL workshop of Quetta (Pakistan).*

The measurements given for the manufacture of the axillar supports and the templates may be a little different. The explanation is that the reproduction technique of the manuals does not always respect the size of the originals. So you have to adjust a little the shape and/or the size of the templates.

Moreover, according to the type of wood you are using, it can be necessary to make the axillar support a little higher.

## Templates for the axillar supports cutting

Child support

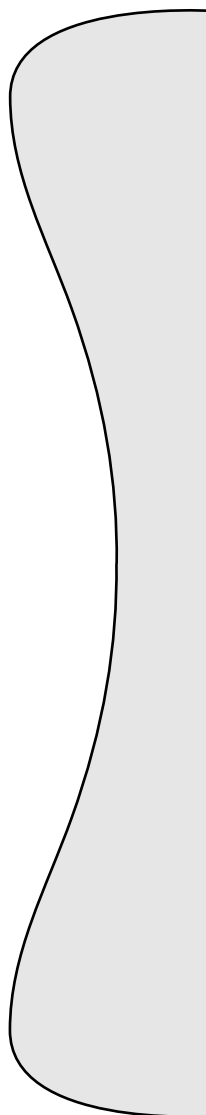

Adult support

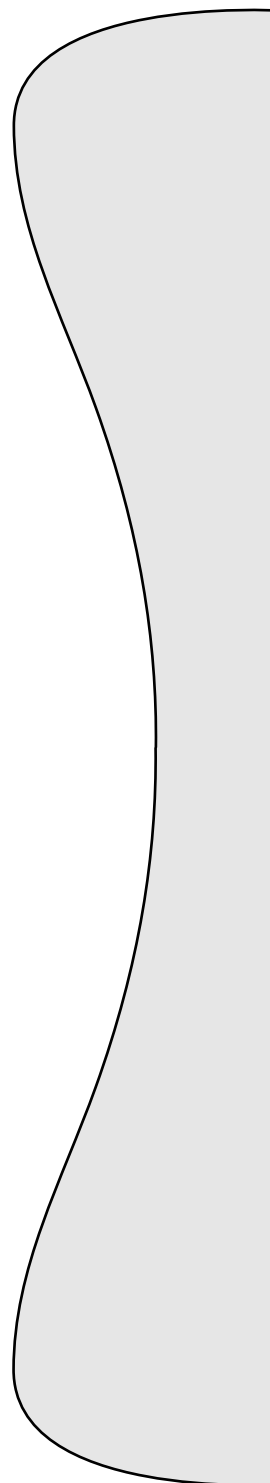

# The adjustable wooden crutch

- Model of a crutch developed at Inhambane (Mozambic)
- For adults and children
- Easily adjustable according to the needs
- Mass production possible thanks to the use of drilling and tracing templates.

The crutch

The different parts of the crutch

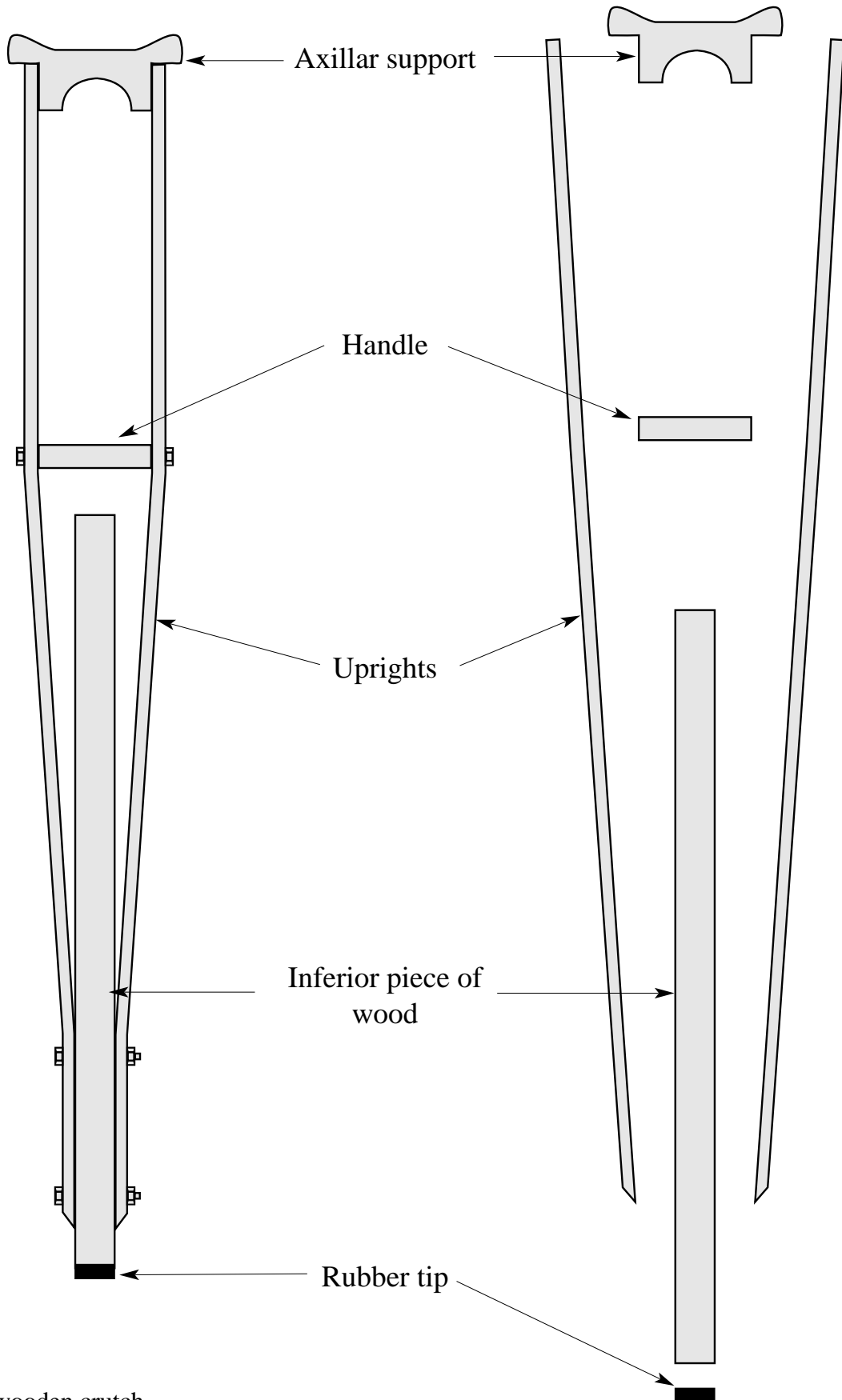

The adjustable wooden crutch

## What do you need to manufacture this crutch ?

### Materials :

**Wood :** You must choose a hard or half-hard wood, solid, supple but not too heavy. Ask the local craftsmen which is the best suited type of wood. For the same quality, always use the lightest wood. Examples of wood used in our workshops : cedar, oak, mulberry tree, eucalyptus, niangou, mahogany, fake-mahogany, yang, umbila...

*Important :* the wood must be dry, have a straight grain and no knots.

**Nails :** 50 et 25mm

**Bolts :** two 6 X 30 mm bolts and two 6 X 80 mm bolts.

**Nuts and washers :** Ø 6mm

**Flat iron 3 mm x 20 mm :** 3 m long  
1 mm thick sheet

**Tyre piece**

**Wood glue**

**Chalk**

### Tools :

Saw

Grater

Wood scissors

Hammer

Mallet

Pincers

Plane

Square

Metre rule

Pencil

Scribe

Drilling machine and  
drill of 6 and 8 mm

Metal cutting saw

File

Center punch

Plate shear

Vice

### Measures :

You must know two measures :

#### **The crutch total height :**

The patient is in standing position, with his shoes (if he is usually wearing shoes) the arms hanging along the body, and the shoulders are down, in natural anatomical position.: neither too high, nor too low. Take the length from the floor to three fingers below the axillar.

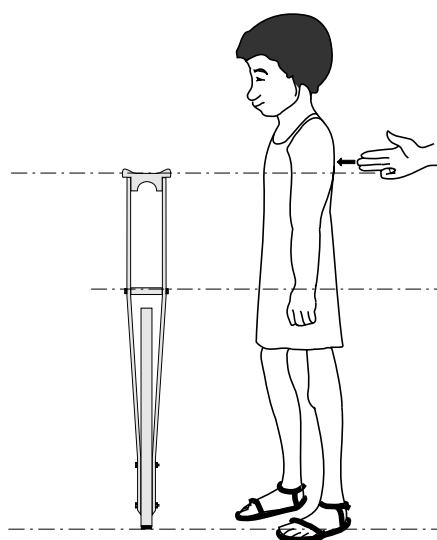

#### **The handle height :**

In the same position, take the length from the floor to the wrist joint : it is the handle height.

All the crutch sizes can be realized from two original models :

- the total height of the smaller model ranges from 76 to 104 cm ;
- the total height of the larger model ranges from 105 to 151 cm.

To manufacture each of these models, you need :

2 templates made in flat iron to drill the adjustment holes :

1 for the uprights,

1 for the inferior piece of wood,

and one tracing template to trace the axillar support.

The adjustable wooden crutch

## First part : Templates preparation

### Manufacture the drilling templates :

here are the diagrams and the sizes of the templates out of flat iron :

#### *Small model :*

Template for the upright length 72 cm

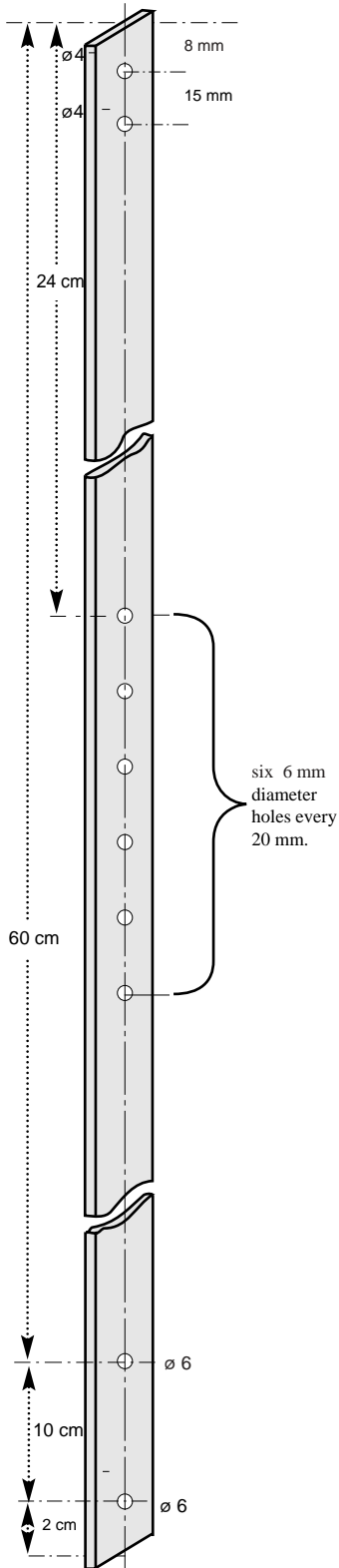

Template for the inferior piece of wood length 44,5 cm

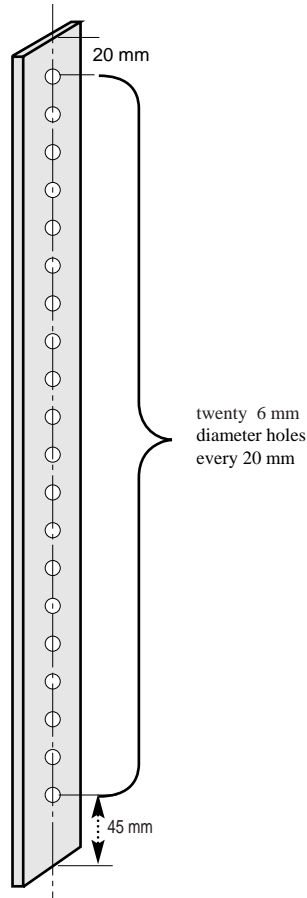

#### *Big model :*

Template for the upright length 1 meter

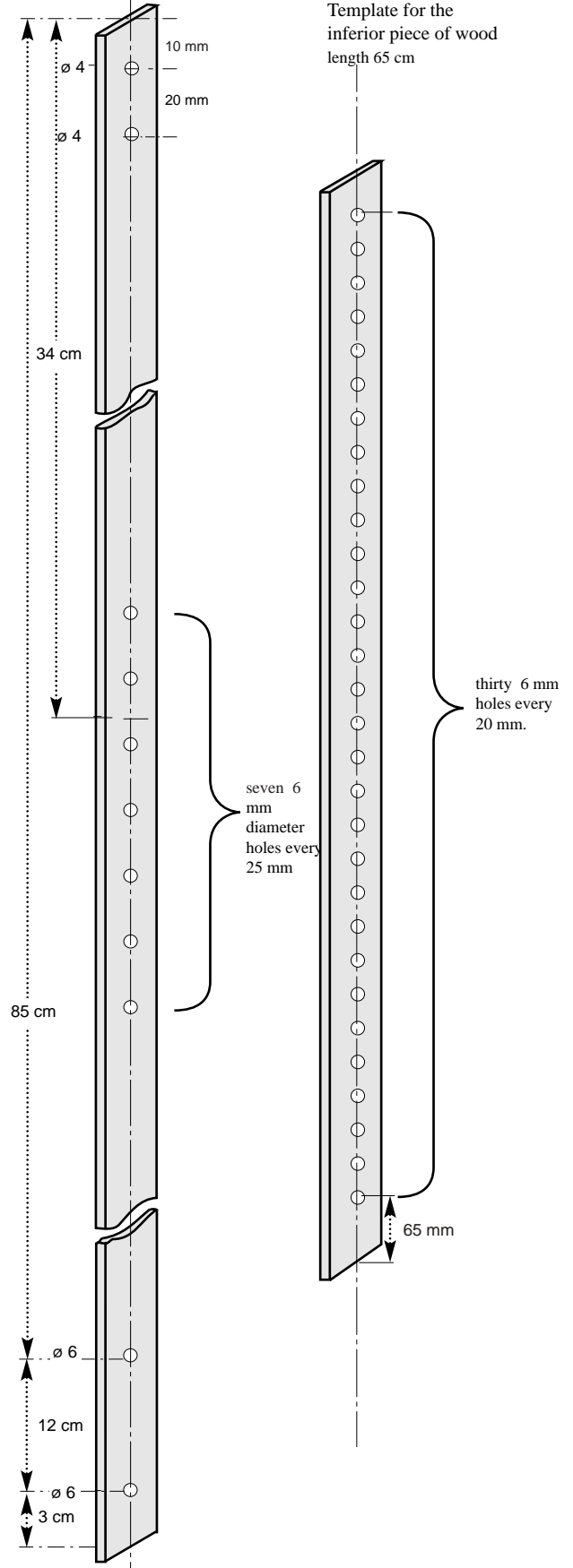

Template for the inferior piece of wood length 65 cm

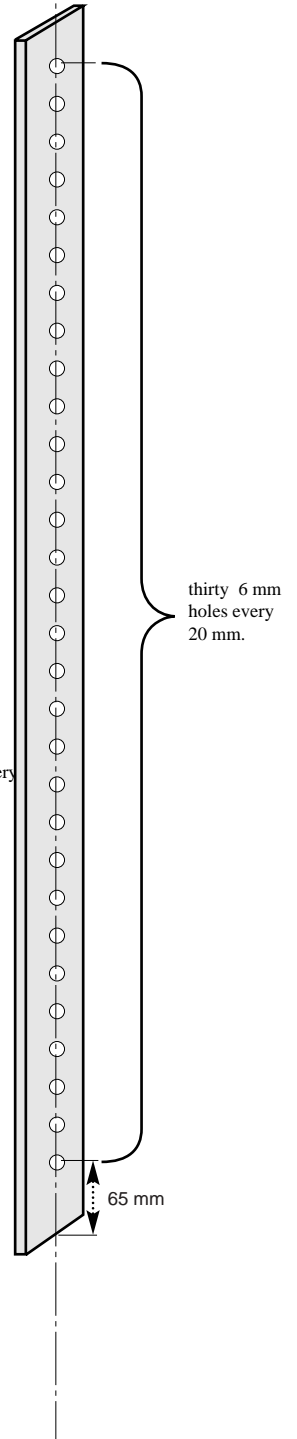

How to make the drilling templates :

- Saw the flat iron according to the given sizes.
- Draw a medial line on the flat iron by rubbing the metal with chalk, then by drawing the line with a scribe or a nail) :

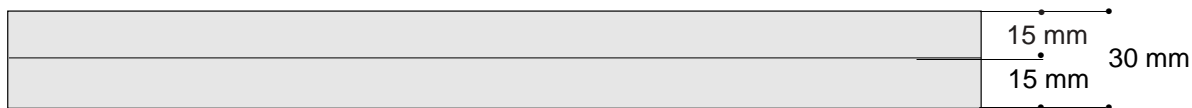

- Copy out the measures of the enclosed diagrams.
- Mark off the center of each hole.
- Drill 4 or 6 mm diameter holes following the diagrams notices (do not forget to add an oil drop on the drill bit when you are drilling so you will not to damage it).
- With a flat file, fettle the metal.

**Manufacture the tracing templates :**

see the diagrams and sizes of the sheet templates :

*Small model :*

Real size :

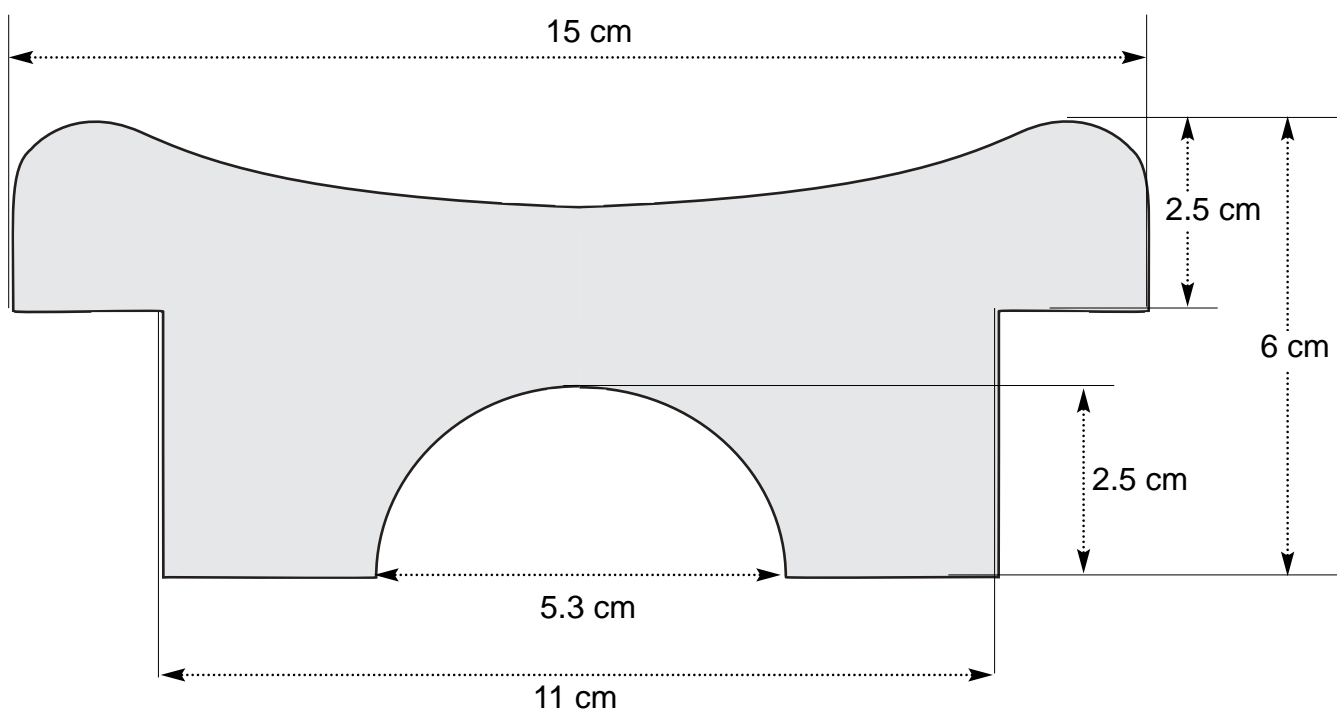

**You can do it more simply**

You are not obliged to hollow out the support. The cutting will thus be easier.

20 The crutch

*Large model :*

Real size

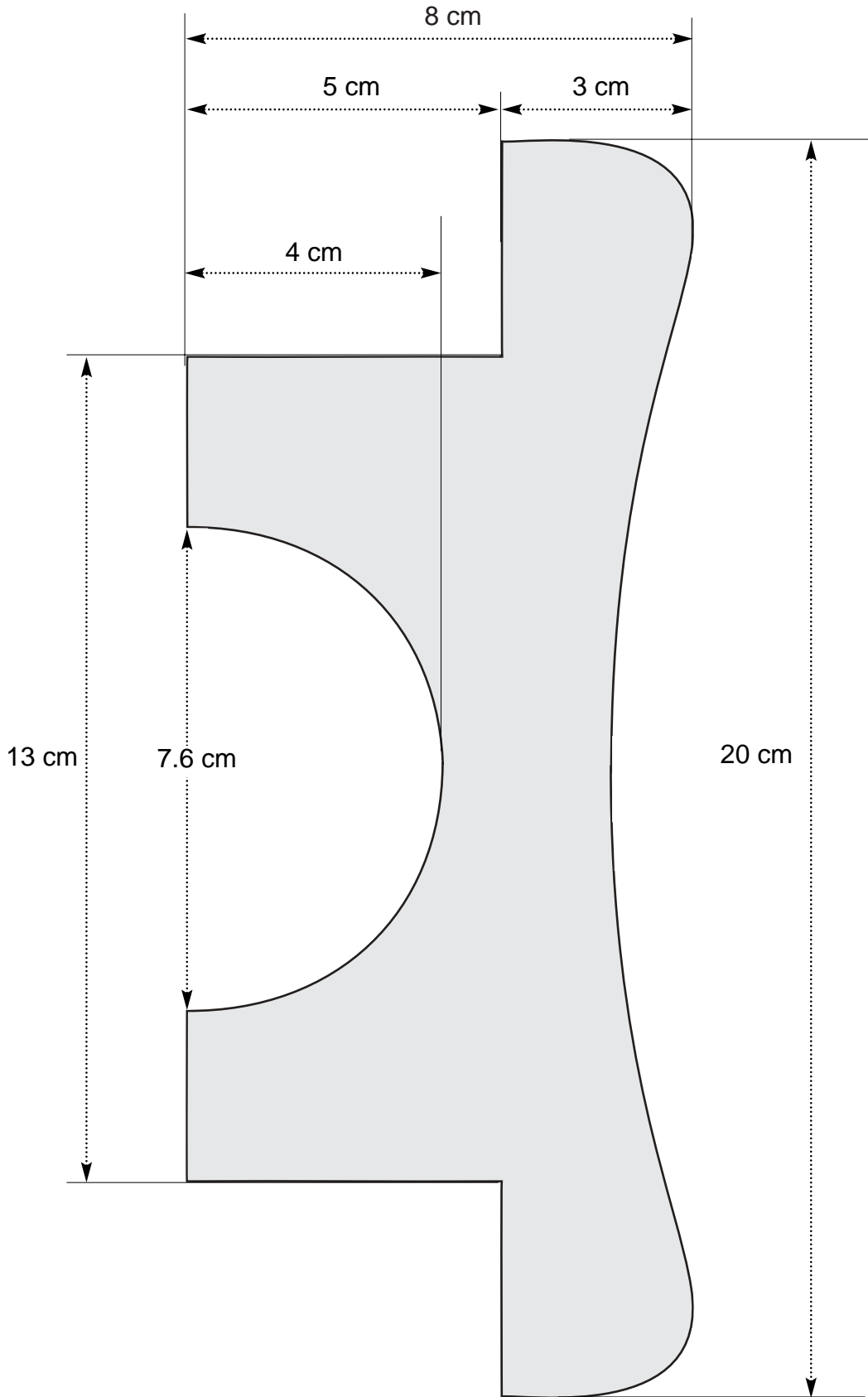

How to make the tracing templates :

- Trace the shapes on a piece of paper (by seeing through a window or with carbon paper).
- Cut the paper.
- Copy out the shapes on the sheet with accuracy.
- Cut the sheet (with the shearing tool or the cutting edge).
- Fettle the sheet with the file.

**Prepare the wood pieces you will need :**

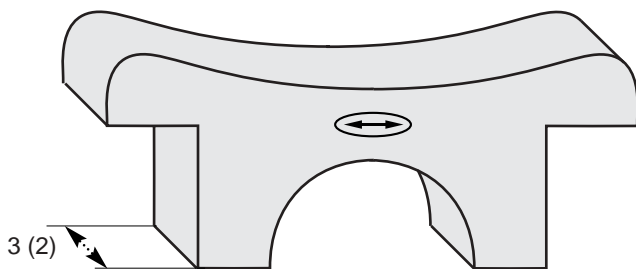
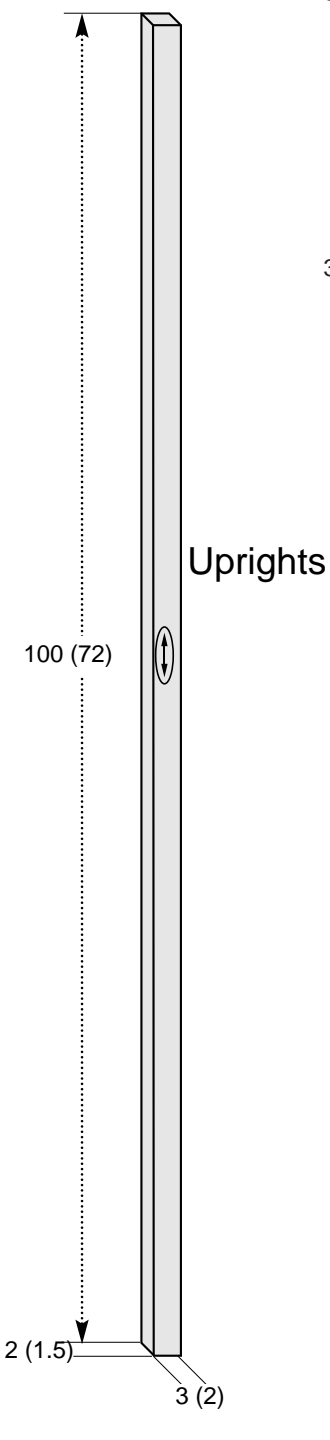

**Axillar support :**

Use the tracing template to cut the support.

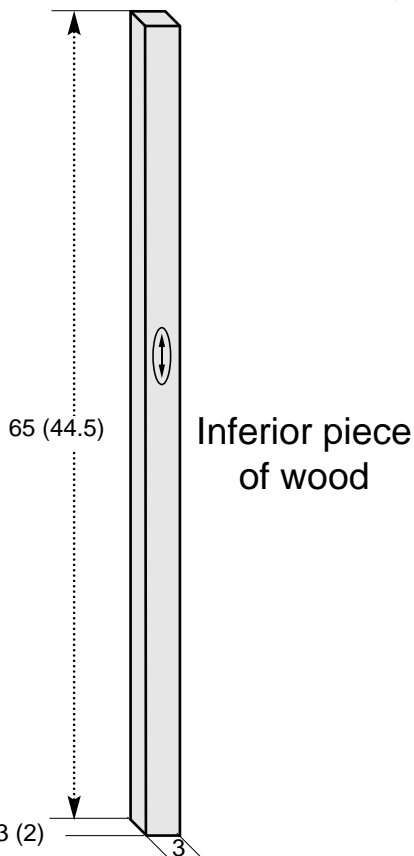
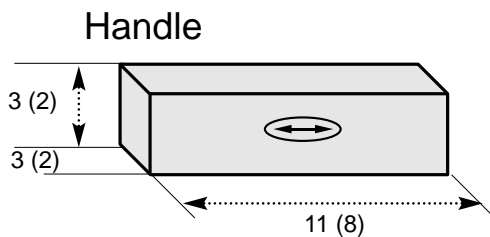

**Dimensions :**

We give standard measure which are fitted for most cases.

On this page, the first measure corresponds to the large model. You will find, between brackets, the measures for the small model.

The drawing dimensions are given in centimeters (cm).

We shall indicate the direction of the wood grain with this symbol.

## 2<sup>nd</sup> part : material preparation

### 1<sup>st</sup> step : drilling of the uprights and of the inferior piece of wood

- Draw a medial line on the inferior piece of wood.
- Put the drilling template of the inferior piece of wood on the wooden piece by taking great care of matching the ends.
- Centre the template following the line drawn on the wood (the medial line must be seen through the template holes).
- Fasten them together so that the template can no more move.

**How to fasten the template**

So as to easily fasten the template, you can drill a small 2mm diameter hole at 1 cm from each end. Once you have placed the template, you just have to nail it down on the wood piece through these small holes. Once you have finished the work, remove the nails.

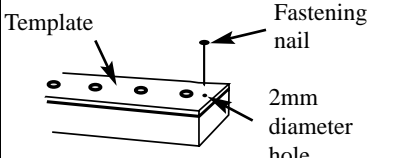

Labels: Template, Fastening nail, 2mm diameter hole

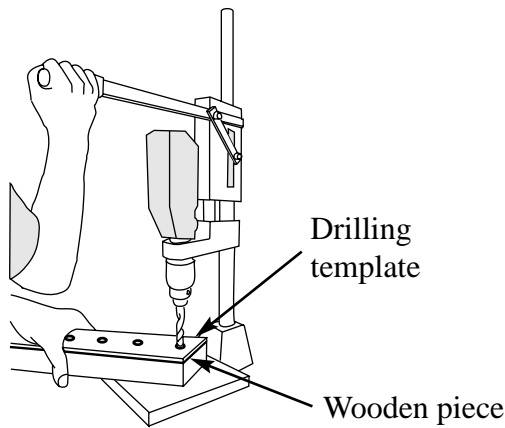

- Drill in the wood the 6 mm diameter holes following the template holes. You must drill throughout the inferior piece of wood.
- Do the same thing with the two uprights by using the drilling template of the uprights.

### 2<sup>nd</sup> step : mounting of the uprights on the axillar support

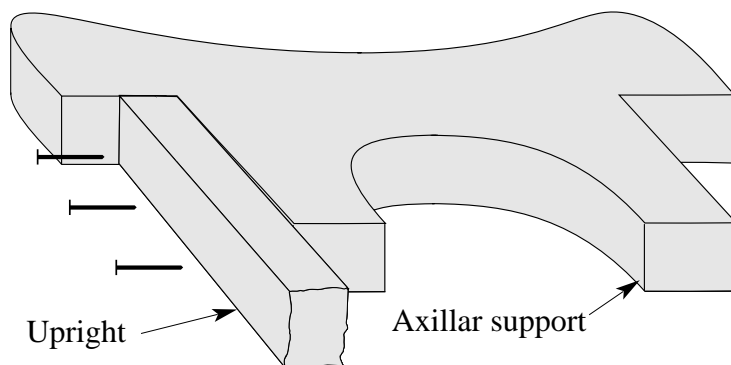

- Paste the pieces of the uprights and of the support which will come in contact with each other.
- Nail the uprights down on the support.
- Wipe out the glue burrs.

### 3<sup>rd</sup> step : handle preparation

Some kinds of wood like Monongo or Merantise may chop when you nail it. If this happen, you should use dowels and glue.

Mark out the centre at each end

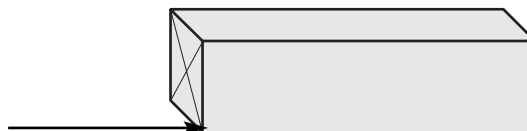

- Drill in the centre with the 6 mm drill bit on a 25 mm depth.
- Then drill with the 8 mm drill bit on a 5 mm depth.

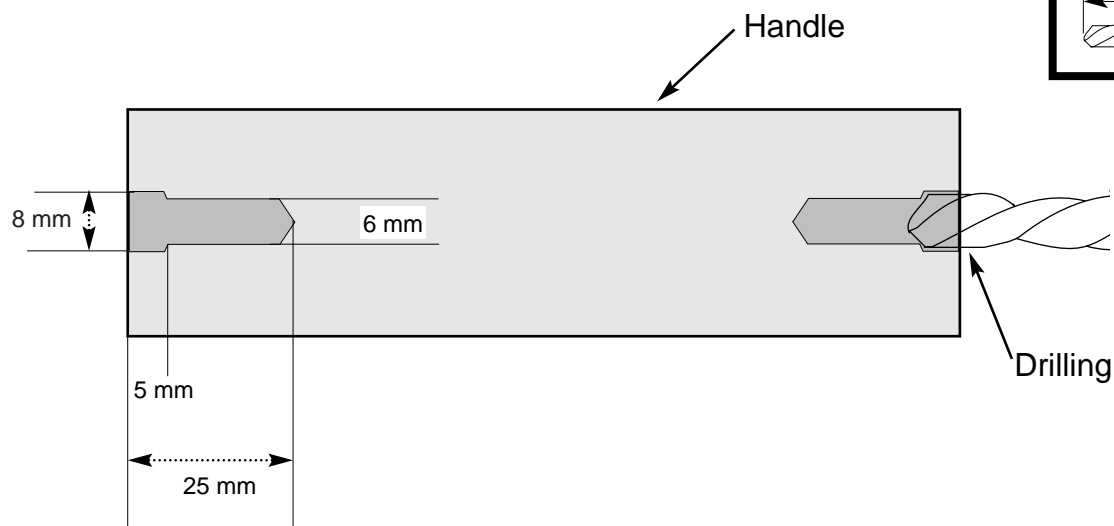
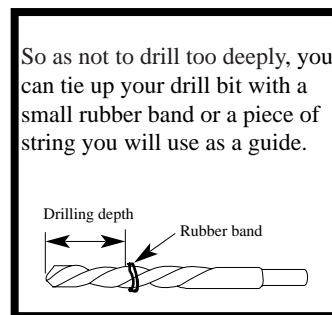

- Force a 6 mm diameter nut into the handle by using a 80 mm bolt as a knocking tool. So as to guide this fitting, the bolt extremity must be at 10 mm from the nut.

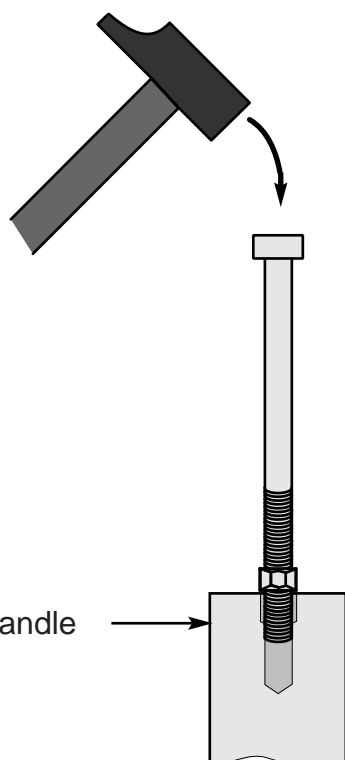
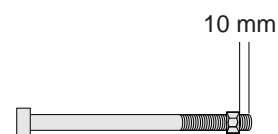

- Unscrew the bolt by letting the nut in its proper place.
- Round off the handle corners.

The fit in bolt must not jut out above the handle

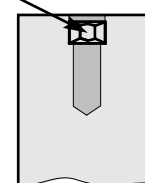

The adjustable wooden crutch

### 4<sup>th</sup> step : Fixing the handle

- Fit the handle between the uprights at the requested place, then fix it with 6 mm diameter bolts by 40 mm length, provided with washers.
- Do not tighten too strongly.

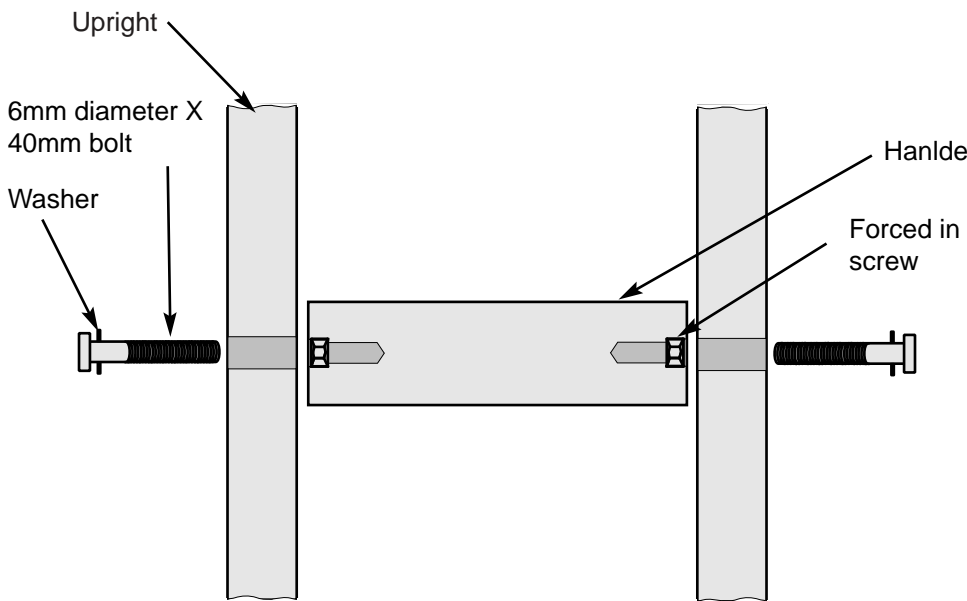

**Important :**

For any bolted assembling, always put a washer between the bolt head (or the nut) and the wood to avoid pulling out the wood.

If you do not have any washer, you can use a small piece of flat iron drilled according to the bolt diameter :



### 5<sup>th</sup> step : Manufacture and fix the rubber tip

It is very important to put a rubber tip on the crutches because it provides a better adherence to a smooth ground and prevents from a quick wear of the inferior piece of wood. We have often seen crutches being worn away by several centimeters within a few months when there was no tip.

- Cut a tyre strip of a size adapted to the tip of the inferior piece of wood. To cut it, use a highly sharpened cutting blade and soapy water to have the blade slide.
- Fix the tyre, the weft side inside, with the help of nails on the inferior piece of wood.

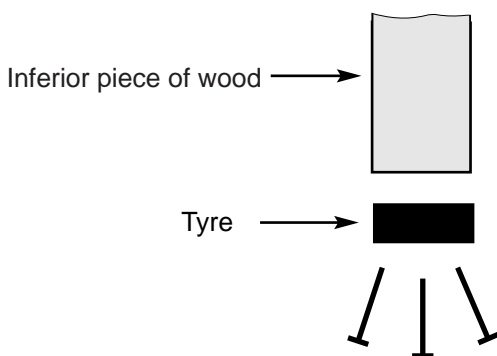

**Alternative :**

To obtain a more resistant tip, you can use a tyre strip gashed on the gum side so as to nail it down on the sides of the inferior piece of wood.

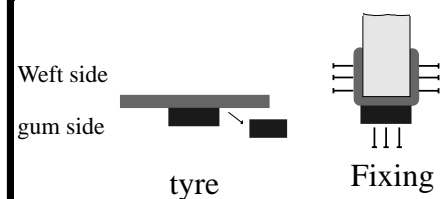

This system avoids the tip to pull out too quickly.

## 6<sup>th</sup> step : How to fix the inferior piece of wood

→ Fix the inferior piece of wood on the uprights with the help of 2 bolts (one at the top and the other at the bottom) + washers and 6 mm diameter nuts.

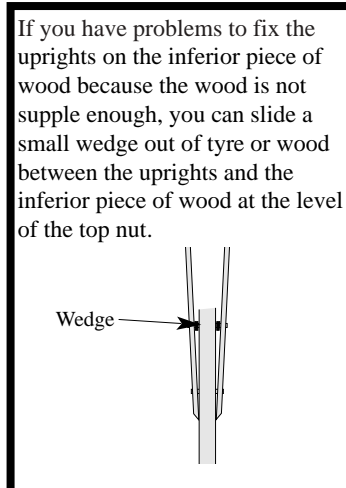
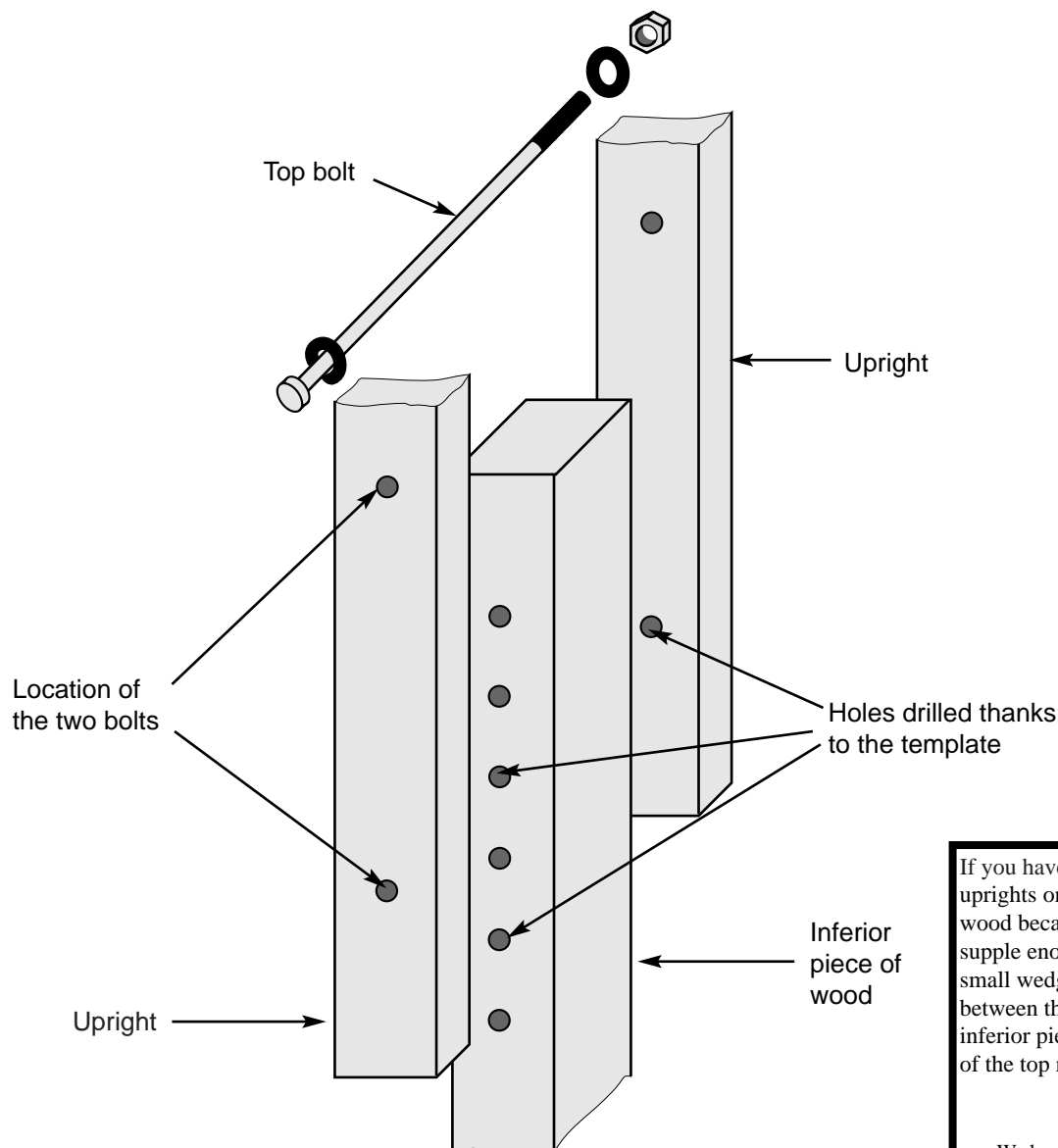

## 7<sup>th</sup> step : finishings

→ Break all the sharp corners with course grained, then fine grained sandpaper or with a scraper.

You can varnish, paint or wax the wood which will thus be less sensitive to humidity and insects.

### OPTIONAL :

You can also stuff the support with rags, kapok, etc..Then cover the support with skai or any plastic cloth which will be fixed with small nails or well sewed.

# The bamboo crutch

- Also called axillar bamboo crutch
- For adults and for children
- Using the traditional techniques in bamboo working
- Model of crutch deviced in Laos

THE CRUTCH (front view)

THE DIFFERENT PARTS OF THE CRUTCH (dismantled view)

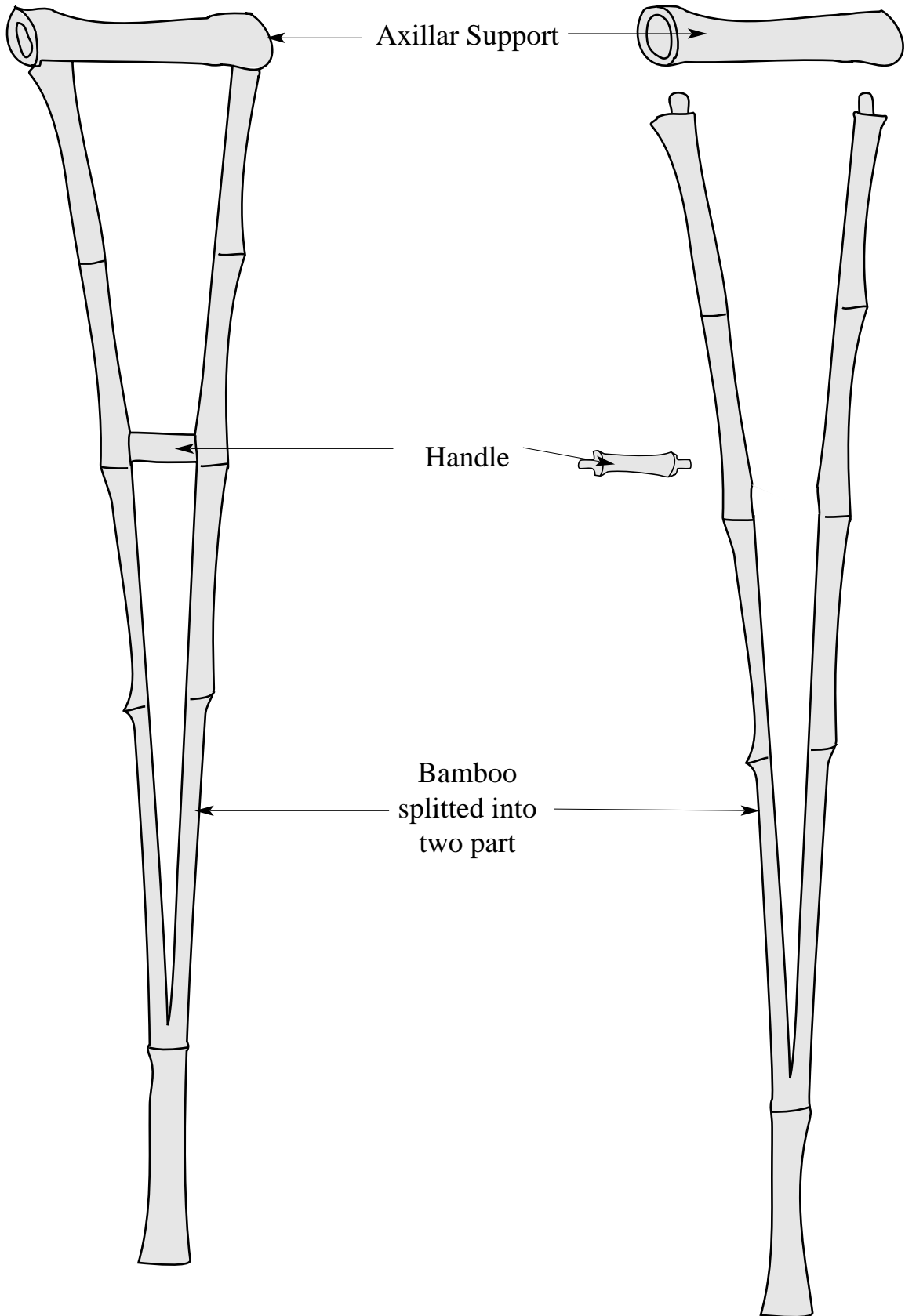

## What do you need to manufacture this crutch ?

### Materials :

**Bamboo** : the bamboo must be matured. In preference, the crown must be very thick. It must be cut during the dry season, soaked in water for several weeks before being dried in a ventilated place. It's external diameter must be at least 4 or 5 cm.

**Rattan, wire, or solid string**

### Tools :

Saw/Machette  
Wood scissors  
Mallet  
Tape measure  
Pencil  
Drilling-machine and Bit or  
Iron heated in fire  
Glue

### Measures :

You must know two measures :

#### **The crutch total height :**

The person is in standing position with his shoes, the arms are hanging along the body and his shoulders must be in normal position : neither too high, nor too low.

The height is equal to the distance between the floor and three fingers under the armpit.

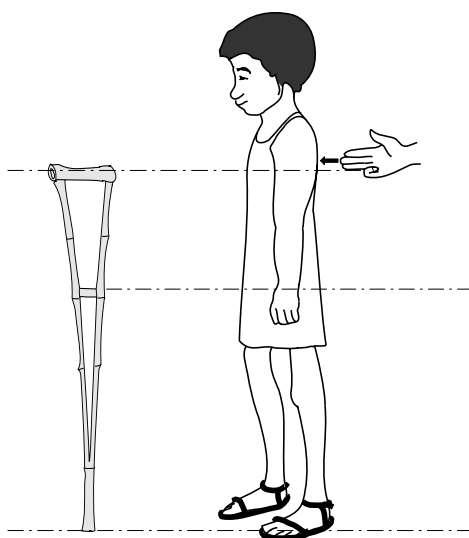

#### **The handle height :**

In the same position, you measure the distance between the floor and the wrist joint. It is the height of the handle.

**1<sup>st</sup> step :** Cut the different pieces which you will need

### *Uprights*

→ For the total height of the crutch, cut a bamboo with a diameter of 4 to 5 cm. At least one of its extremities must be cut just after a node.

### *Support*

→ From a bamboo of 4 cm of diameter, cut a piece of 20 cm long for adults and 15 cm long for children.

### *Handle*

→ Cut from a solid bamboo, with a diameter of 3 to 4 cm, a piece of 13 cm long for adults or 10 cm long for children.

In our workshop in Tuléar in Madagascar, there is no solid bamboo. We are using instead a piece of round wood inserted into the bamboo.

The bamboo crutch

**2<sup>nd</sup> step** : Prepare the parts

→ Split the big bamboo up to 25 cm from the end where the node is found. If you can, stop the split right just above the node.

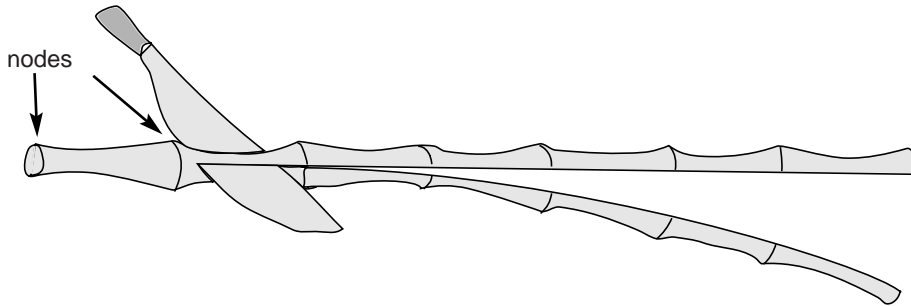

**Craftily :**

You can make a hole with a drill or red-hot iron before splitting the bamboo. The hole will serve to stop the split line, and to avoid that the bamboo continuously divides into two.



→ Cut a hole 1,5 cm from each end of the support. Adjust the mortises to the tenons of the uprights.

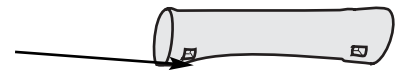

→ Clear a tenon of 3 cm from each end of the uprights.

→ At 1 cm below the tenons of the uprights, drill a hole of 6 mm in diameter.

→ In each end of the handle, clear a round tenon of 1 cm in diameter by 2 cm long.

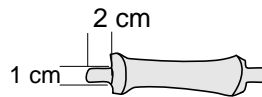

→ Drill a hole of 1 cm diameter in each uprights of the level of the wrist height plus 2 cm.

→ Tightly bind the tip of the split line with a rattan or wire.

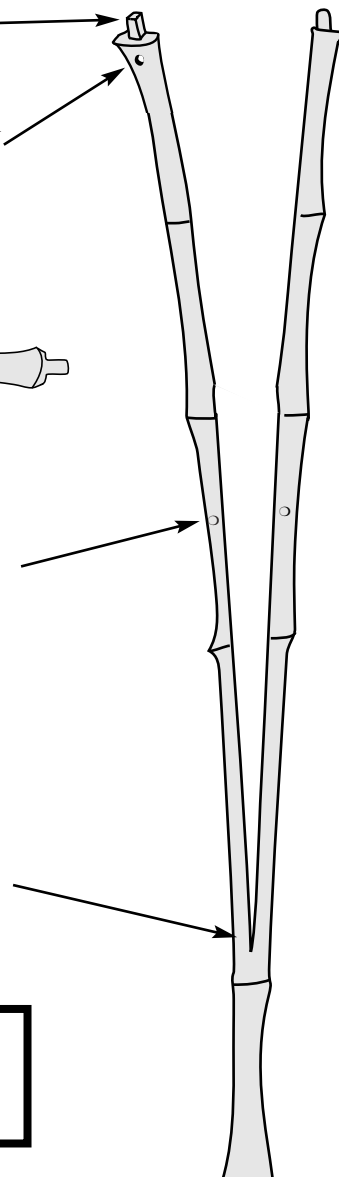

When you are using a bamboo which is not totally dry, it is necessary to tighten regularly the wire splice at the split end because the bamboo continuously diminish in diameter little by little until it is completely dry.

### 3<sup>rd</sup> step : Assembly

- Glue the tenons of the handle.
- Insert strongly the handle to the hole of the uprights.
- Glue the tenons of the uprights.
- Position the support and insert the tenons inside the mortises.
- Fix them together with a cord or a rattan.
- In order to avoid sharp edges, smoothen the angles of the bamboo.

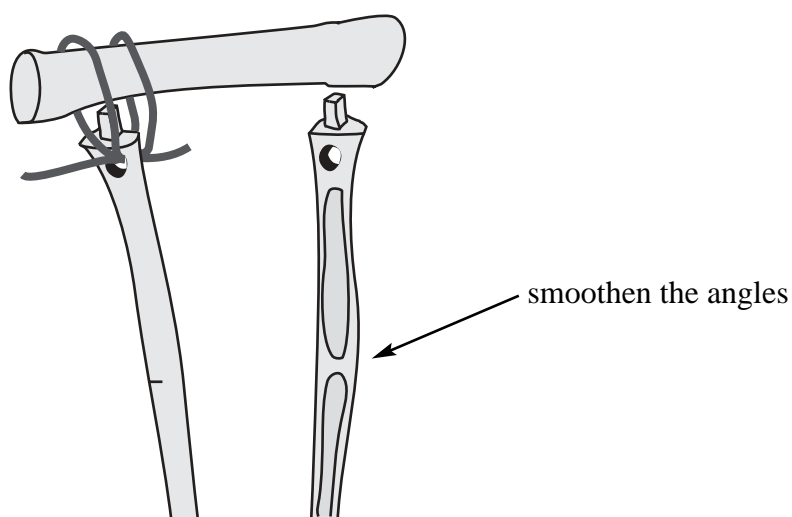
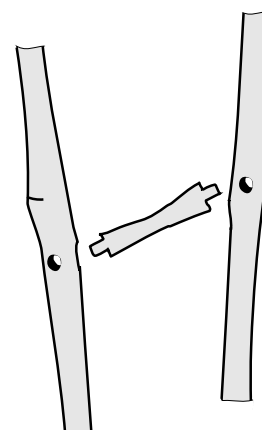

In Madagascar, the variety of bamboo which is very well adapted to the fabrication of this crutch is with a deep yellow color with some green stripes in the length direction. In effect, it is very hard and acquires a thick crown.

Designed and published by

*Service des Editions Techniques*  
**HANDICAP  
INTERNATIONAL**

ERAC  
14, avenue Berthelot  
69361 Lyon cedex 07  
FRANCE  
Tél. : 78.69.79.79

**With the support of "La Fondation de France"**

**Price : 30 Frs**  
**ISBN : 2-909064-09-3**